

## DMX to Serial Adapter v.1b

This device reads a DMX-512 signal and grabs a variable amount of channel data values and sends them at 57600 or 19200 baud to an external device, such as a 24 Channel High Current LED Controller, when a new data packet is requested. This allows any microcontroller(PIC, Arduino, ATMel, ect.) with TTL serial communication to accept DMX-512 data without the overhead of decoding the DMX signal and grabbing the necessary data values.

This is done utilizing two enhanced Mid Range PICs, a 12F1822 and a 16F1828. The 16F1828 reads the DIP switch to get the DMX address, reads the DMX-512 signal and saves the desired channel data to RAM. It signals to the 12F1822 to reset its buffer then sends the DMX channel data to the 12F1822 at 250k baud(DMX speed). The 12F1822 accepts the data from the 16F1828 and waits for the external device to reset its buffer and signal a request for a new data packet. When the 12F1822 receives a data request it switches from 250k baud to 57600(default, 19200 firmware available) and sends the DMX data values as standard TTL serial bytes to the external device. The external device then does what it needs with the data, and requests a new packet when it is ready.

This was designed to interface serial devices as stated, but has the hardware and firmware to use it as a DMX development platform for transmission or reception (or both) purposes.

### Features:

- Reads DMX-512 signal and converts to easier to utilize data.
- Interfaces through standard TTL UART. Easy to connect to other microcontrollers.  
(PIC, Arduino, ATMEL etc.)
- Configurable DMX-512 Signal Boost
- Fast packet acquisition and transmission
- Implemented DMX transmission hardware and firmware, in addition to standard reception.
- Source Code Available(written in Assembly)

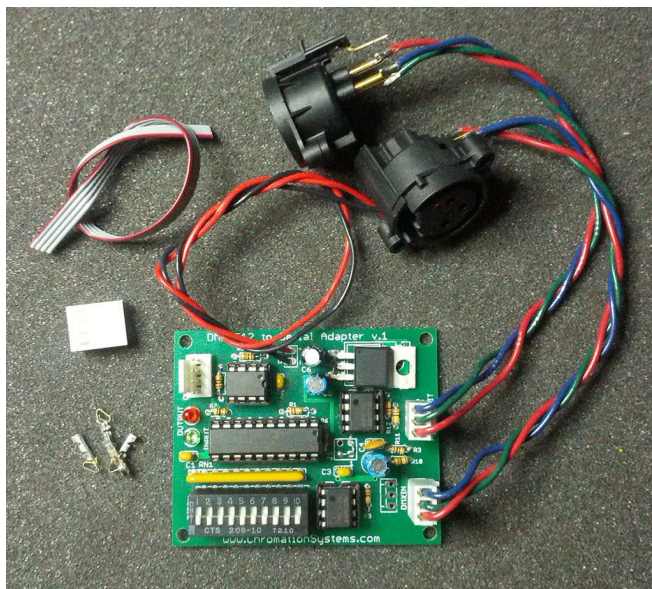

### Specification:

<b>Controller Input Voltage</b>	<b>5v*, 7v - 35v**</b>
<b>Current Draw</b>	<b>&lt; 100mA</b>
<b>Output Baud</b>	<b>57,200 Default, Varies</b>
<b>Connectors</b>	<b>0.1" Pitch</b>
<b>Dimension</b>	<b>2" x 2.5" x 0.5"</b>

\* 7805 Voltage regulator should not be installed, and positioned jumped.

\*\* Requires the 7805 be installed.

PIC16F1828	
PIC12F1822	
RS-485	SN75176
RS-485	SN75176
DIPSW	CT20810-ND
C1	0.1uF Disc
C2	0.1uF Disc
C3	0.1uF Disc
C4	0.01uF Disc
C5	1uF
C6	10uF
C7	1uF
7805	LM7805
INPUT	3mm LED
OUTPUT	3mm LED

R1	10k ohm
R3	100k ohm
R4	1k ohm
R5	10k ohm
R6	100 ohm
R7	1k ohm
R9	100k ohm
R10	10 ohm
R11	100k ohm
R12	100k ohm
RN1	4611X-101-103LF

- 1: XLR Pin 1(GND)
- 2: XLR Pin 2
- 3: XLR Pin 3

- 1: SendIO, pulsed by external device.
- 2: Ground Reference
- 3: Transmit(TX) connect to external device's RX, or SPI SDO
- 4: Unused normally, or SPI Clock

All resistors 1/6w

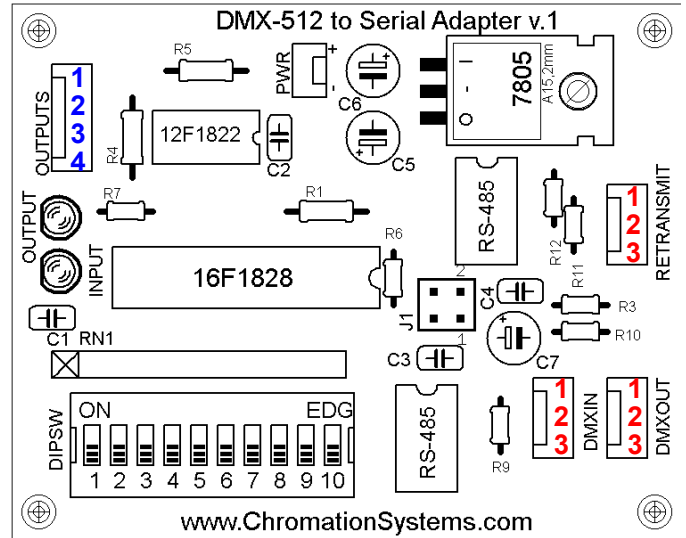

If RETRANSMIT is utilized, a 120 ohm termination resistor should be soldered across XLR Pins 2 & 3.

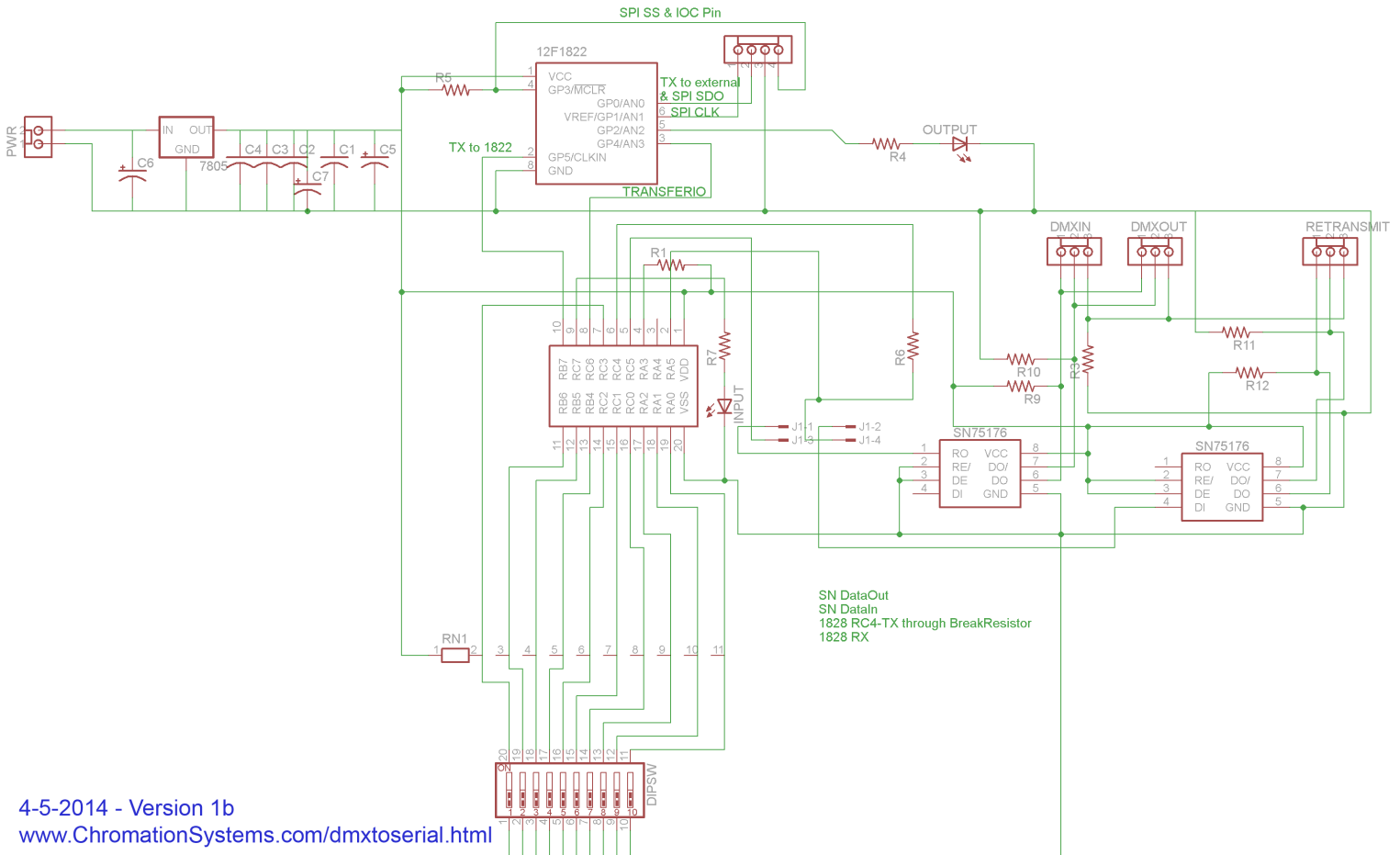

## Jumper Configuration:

**Retransmit:** Incoming DMX data signal is read and sent(cloned) without modification. The DMX in connector connected to DMXIN, the DMX out(female) connected to RETRANSMIT. Must install the 120 ohm termination resistor on DMX In.

**Passive Reception:** DMX Data is only read, DMX input and output connectors are in parallel. No 120ohm termination resistor.

**Normal Reception, Firmware Retransmit:** DMX input is read, a firmware generated DMX universe is transmitted, firmware can be written to convert, reorganize, or perform mathematical functions on incoming data and transmit the edited universe, or a generated universe. Must install the 120 ohm termination resistor on DMX In.

**Firmware Swappable:** Not implemented on hardware as it was not considered during design. But a NPN transistor (2n3904 or similar) can be used to switch between Retransmit and Normal Reception, Firmware Retransmit modes during runtime. Firmware is implemented but the hardware has to be added. Must install the 120 ohm termination resistor on DMX In.

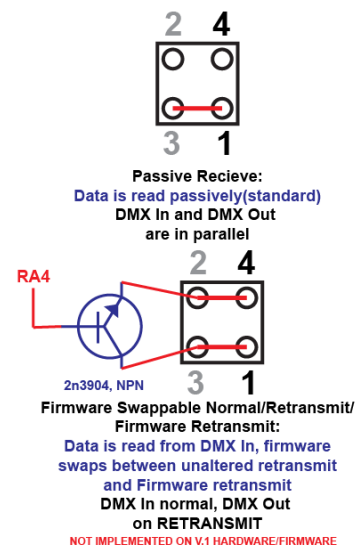
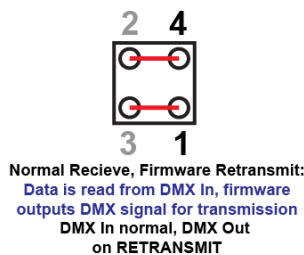
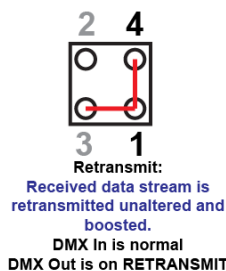

## Firmware:

Compatible Chromation Systems LED Controllers can be used or a simple communication protocol could be written to work with an Arduino or any other type of microcontroller system. SPI Hardware is enabled but current firmware does not support it. Contact for help if SPI Output is required.

The source code and MPLAB project is included with purchase of a kit, and is available for download for a small fee. Written in Assembly for maximum efficiency. Full image preview available.

Sending a pulse of at least 1uS to Pin 1 of the Output Header, will signal to the 12F1822 that the external device is ready for a new data packet and has reset it's buffer, it then sends default of 24 bytes(firmware can be modified for more or less bytes) out at 57,600 baud(also could be modified) over it's TTL UART once it has collected the data packet from the 16F1828.

The current version of the firmware will attempt to transmit a firmware generated universe on DMXout if DIP Switch 10 is On, leave DIP 10 off if using adapter normally.

**Please Contact [Support@Chromationsystems.com](mailto:Support@Chromationsystems.com) with any questions or comments.**